

FIAT 8V

8 cylinders

4 independently sprung wheels

2 seats

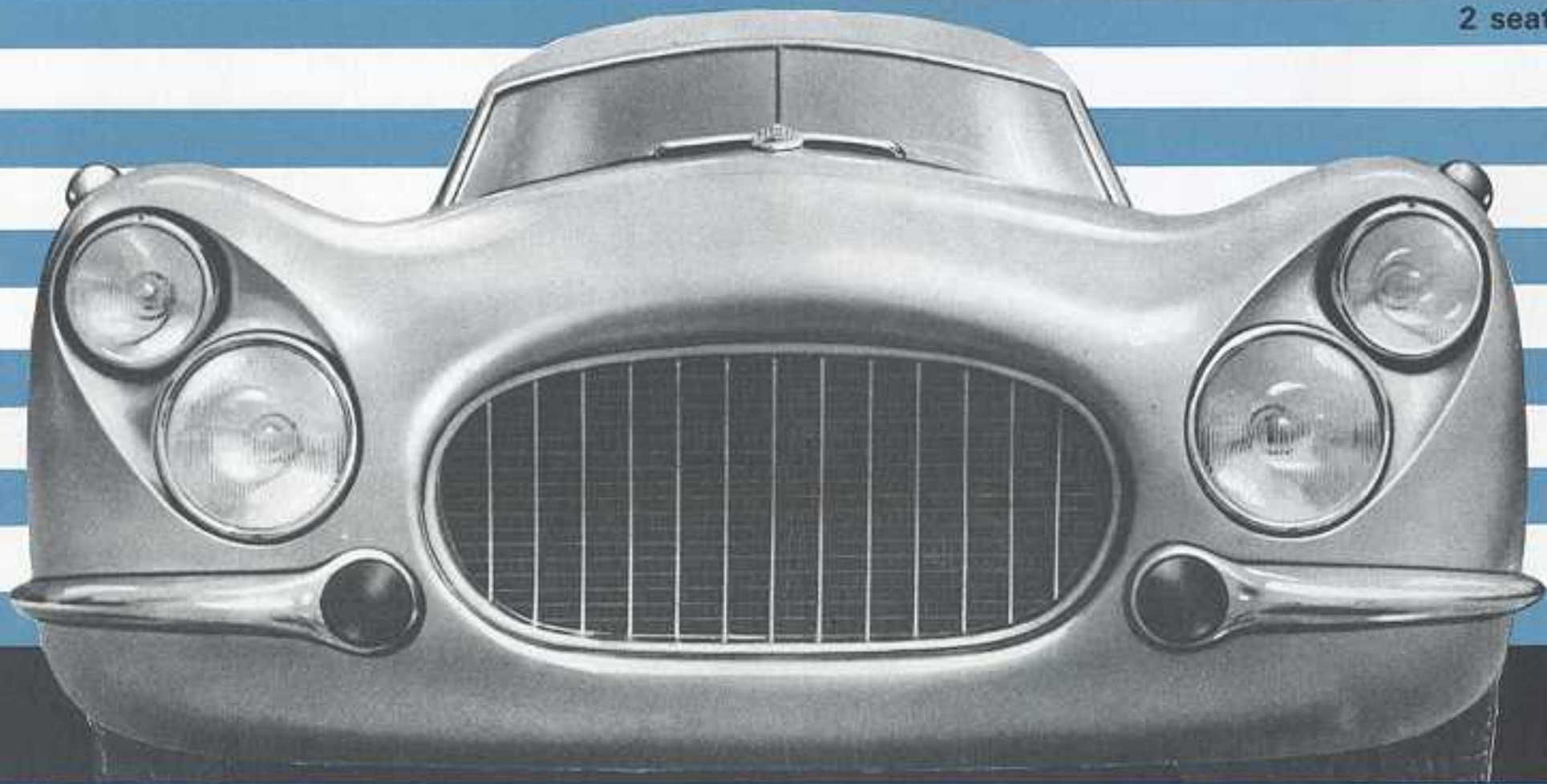

Engine - 4-stroke, 8 cylinder 70° V, bore 72 mm., stroke 61.3 mm., cubic capacity 1996 cc. 110 h.p. at 6000 revs. per min. Compression ratio 8.5 to 1. Forced lubrication with oil cooling radiator. Indirect cooling with forced water circulation. Battery ignition. Two twin-body Weber carburettors. 12 volt electric starter.

Clutch - single plate, dry.

Gearbox - 4 forward speeds and reverse, conventional lever control. 2nd, 3rd and 4th speeds synchronised.

Gear ratios: 1st 2.694 - 2nd 1.768 - 3rd 1.257 - 4th 1.

Rear axle - Independently sprung wheels and final drive group fixed to the frame. Ratio 9/40.

Front suspension - Independent wheels with transverse wish-bones and coil reaction springs enclosed in a casing. Telescopic hydraulic shock absorbers and transverse stabiliser bar.

Rear suspension - Exactly similar to the front suspension.

Brakes - Hydraulic, pedal operated, acting on all four wheels with special internal cooling arrangement. Hand brake on the transmission.

Wheels - Spoked, with Whitworth locknuts, centred on cones.

Tyres - Special 165-400 tyres front and rear.

Frame - Of steel tubes integral with the body.

Fuel tank - capacity 17 1/2 Imp. galls. (80 liters).

TECHNICAL AND PERFORMANCE DATA

Construction of the body

Inner shell

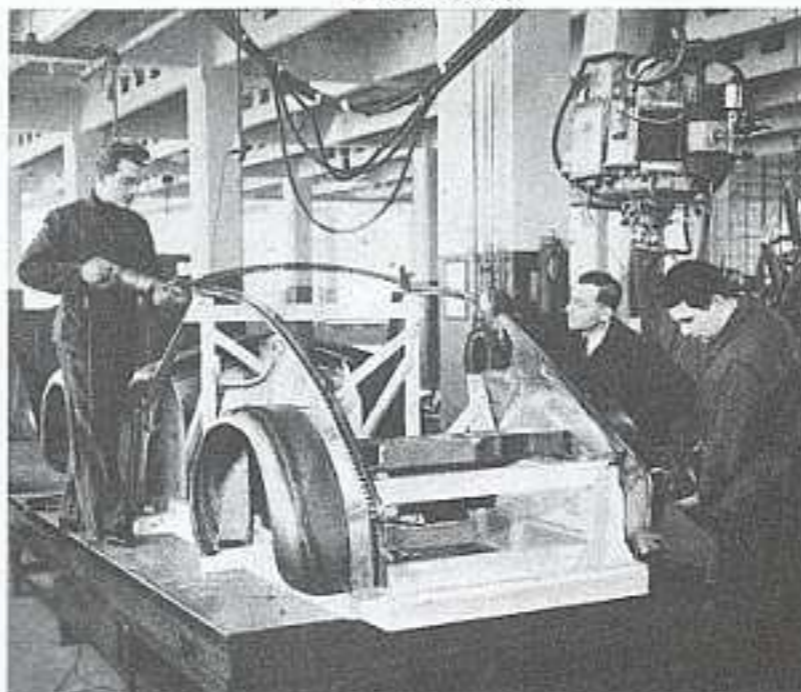

Outer shell

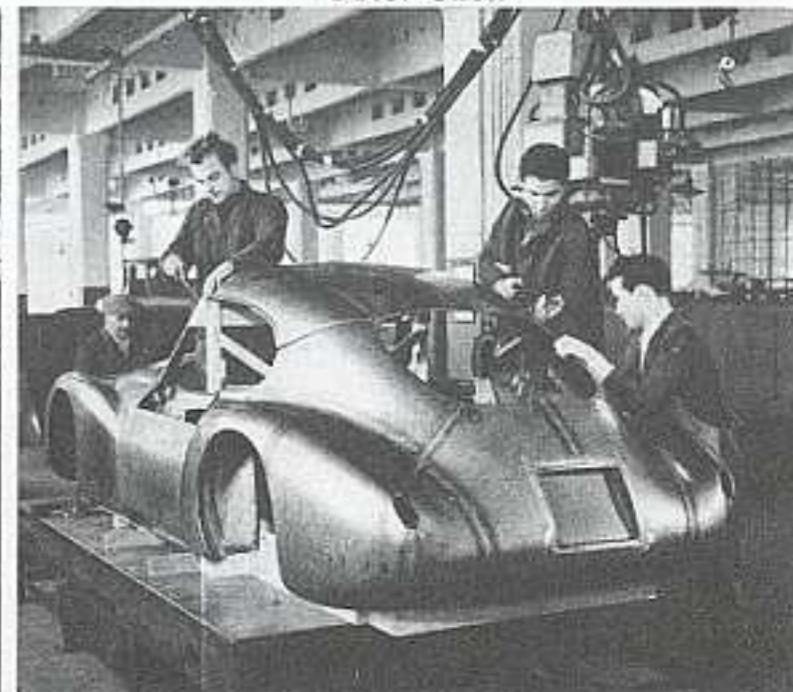

Track: front 50.3/4" (1290 mm.) rear 50.3/4" (1290 mm.)
Wheelbase: 94 1/2" (2400 mm.)
Overall length: 158 1/2" (4030 mm.)
Overall width: 61 3/4" (1570 mm.)
Overall height, fully laden: about 51 1/2" (1305 mm.)
Weight (without supplies): 2050 lbs (930 kg.)
Maximum speed with 9/40 rear axle ratio: about 112 miles (180 km.) per hour.
Distance run without refuelling: about 248 miles (400 km.)

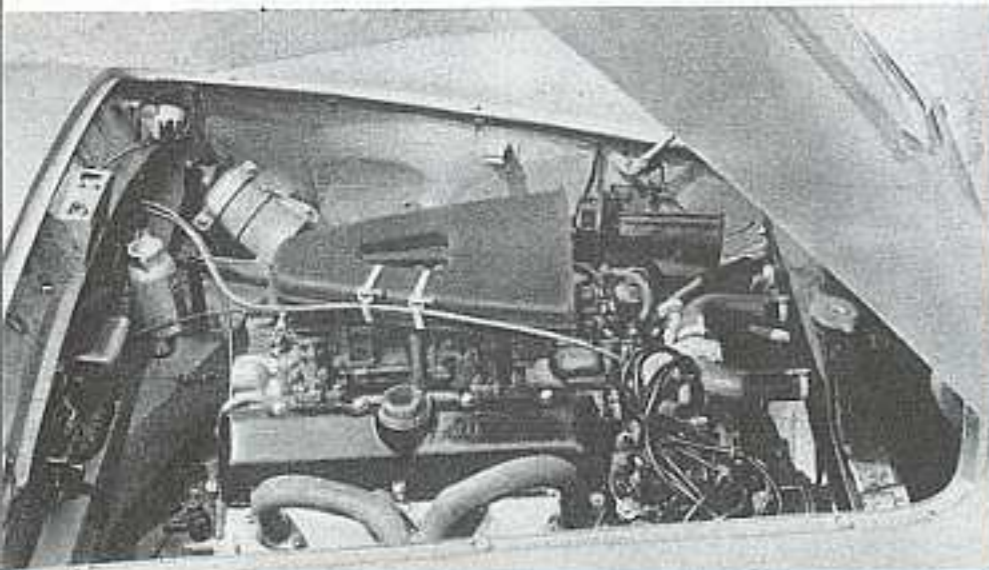

A PEEP UNDER THE BONNET

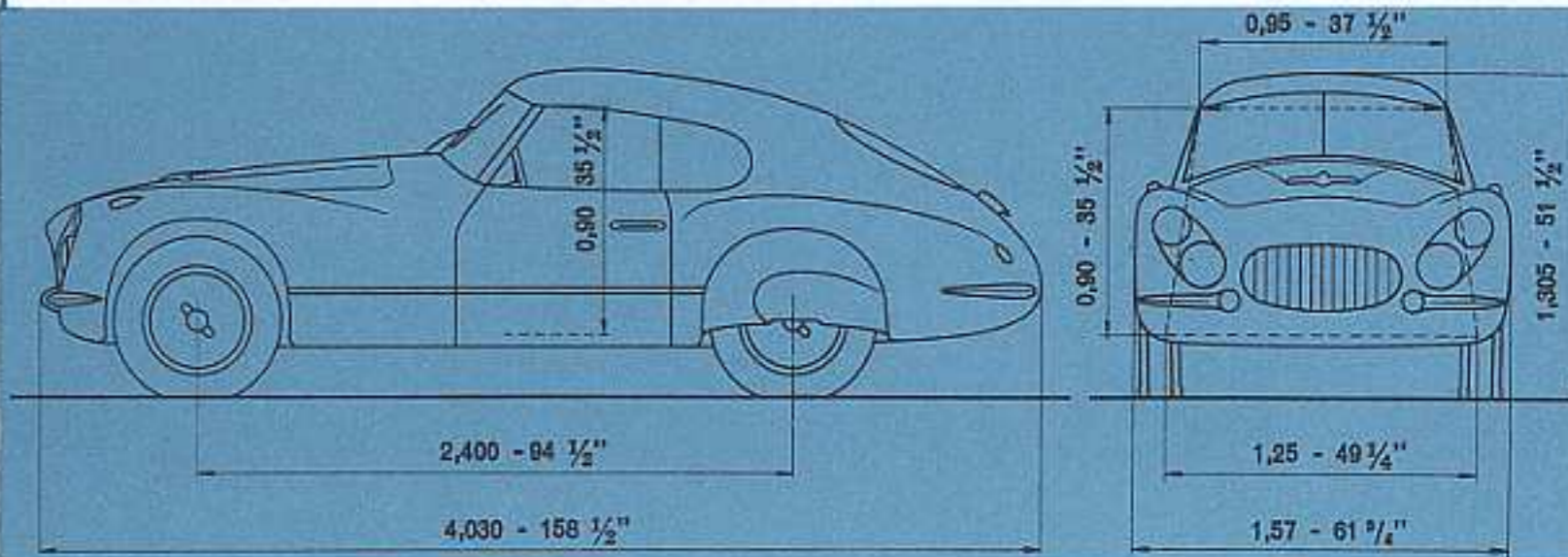

The descriptions and illustrations in this folder are simply general indications, and are not binding.

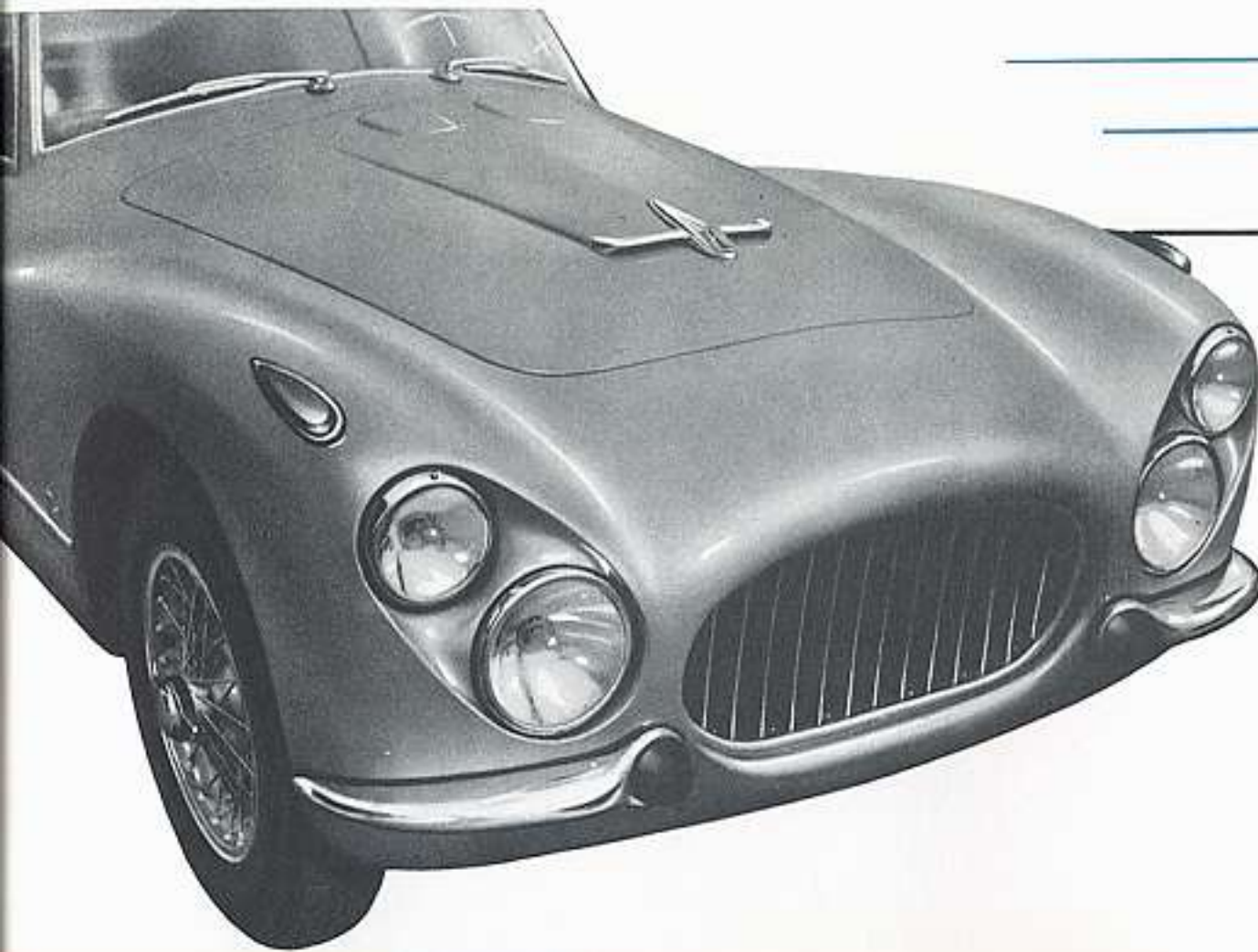

The body, of the integral type welded to the tubular frame members, consists of two sheet steel shells, an inner shell and an outer shell, welded together so as to form the box shaped stressed members. Outside finished in metallised colour. Bumpers, radiator grille and mouldings in polished stainless light alloy. Curved windscreen with safety glass. Crank operated drop windows in the doors. Upholstery and interior finish in imitation leather. Roof covered with a special heat and noise insulating material. Spare wheel carried inside the car. Independent headlights complying with ISO international regulations. Instruments: rev. counter, clock, speedometer, petrol gauge and oil pressure gauge.

Models for wind tunnel tests of the body. On the upper model the fluid flow lines are clearly visible; on the lower one the positions of the centre of gravity and of lateral pressure can be seen.

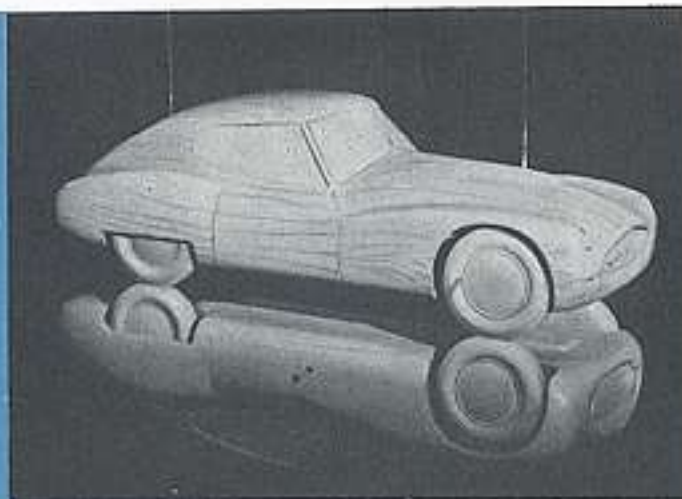

The streamlining of the "8 V.": designed by the wind

