

Allegato 5

Autocarrozzeria NUOVA LAS snc
 via Bologna 316 H
 59100 PRATO (PO)
 Tel: 0574-460304
 Fax: 0574-695383
 P.I.: 00256980970

Spett.le
 STEFANO RICCI S.P.A.
 VIA DE' NICCOLI 26
 50137 FIRENZE FI
 C.F. 01674990484 P.I. 01674990484

Tipo documento: Fattura	Numero: 175	Data: 29/03/2011	Valuta: EURO
Veicolo: ASTON MARTIN LTD	Targa: AH 25-19		
Pagamento:	Banca:		

Natura/Qualita' dei beni o servizi	Q.ta	Prezzo	Importo
RESTAURO AUTO D'EPOCA TELAIO LML906	1,00		
STACCO DI TUTTE LE PARTI ACCESSORIE DELLA CARROZZERIA INTENE ED ESTERNE.	1,00		
RIPRISTINO DELLA SCOCCA COMPLETA CON RIPIRTO A METALLO DELLE PARTI OCCORRENTI	1,00		
PREPARAZIONE ALLA VERNICIATUR A REGOLA D'ARTE DELLA SCOCCA ESTERNA E PARTI INTERNE	1,00		
VENICIATURA TOTALE CON MATERIALI DELLA MIGLIORE QUALITA'	1,00		
RIASSEMBLAGGIO DI TUTTE LE PARTI DELLA CARROZZERIA ED ACCESSORI	1,00		
TOTALE COMPRESO MATERIALI	1,00	14.874,00	14.874,00

DETTAGLIO IVA				TOTALE DOCUMENTO	17.848,80
Aliquota	Descrizione	Imponibile	Imposta		
20	20%	14.874,00	2.974,80		
				Pag.	1

Autocarrozzeria NUOVA LAS snc
via Bologna 316 H
59100 PRATO (PO)
Tel: 0574-460304
Fax: 0574-695383
P.I.: 00256980970

Spett.le
STEFANO RICCI S.P.A
VIA FAENTINA 171 LOCALITÀ CALDINE
50010 FIESOLE FI
C.F. 01674990484 P.I. 01674990484

Tipo documento: Fattura	Numero: 272	Data: 02/05/2012	Valuta: EURO
Veicolo: ASTON MARTIN LTD	Targa: ZB145AC		
Pagamento: Ri.Ba. 60 gg. D.F.F.M.	Banca: CASSA DI RISPARMIO LUCCA PISA LIVORNO FIL. FIRENZE ABI 6200 CAB		

Natura/Qualita' dei beni o servizi	Q.ta	Prezzo	Importo
AUTO D'EPOCA TELAIO LML906	1,00		
PERFEZIONAMENTO DI ALCUNE PARTI DELLA CARROZZERIA ESTERNA ED INTERNA	1,00	2.500,00	2.500,00
PER TRASPORTI CON NOSTRO CARROATTREZZI	1,00	700,00	700,00

DETTAGLIO IVA			
Aliquota	Descrizione	Imponibile	Imposta
21	21%	3.200,00	672,00

TOTALE DOCUMENTO 3.872,00

Pag. 1

CEDENTE O PRESTATORE, DOMICILIO O RESIDENZA, CODICE FISCALE, PARTITA IVA

INTERNI D'AUTO IL PAPERINO
 di Polvani Gianluca
 Via Pisana, 146
 Tel./Fax 0577 934150
 53036 POGGIBONSI (SI)
 C.F. PLV GLC 69A31 G752T - P.I. 01174430528

RICEVUTA FISCALE
 FATTURA (RICEVUTA FISCALE)

Numero attribuito **38**
 Data **19-04-2012**

DATI IDENTIFICATIVI DEL CLIENTE

STEFANO RIECI SPA VIA FAENTINA 171
LOC. CALDINE 50010 FIESOLE FIRENZE

CODICE FISCALE

PARTITA IVA

01674990484

QUANTITÀ	NATURA E QUALITÀ DEI BENI O SERVIZI	IMPORTO
	Rifacimento interno completo, con moquette, pelle e materiali vari. Ricostituzione della capote in scumelland	
	ASTON MARTIN ZB 145 AC	€ 11.566,39
	Pagato Polvani Gianluca	

DD.MM. 30 MARZO 1992 Art. 12 comma 1 Leg. 30/12/1991 N. 413

Tipolitografia A. SPADA - Stabilimento: 01037 Ronciglione (VT) - Via Marco Polo, 8 - Aut. Min. Fin. n. 366.028 del 18.10.79

DETTAGLIO IVA	ALIQUOTA	IMPONIBILE	IMPOSTA	Corrispettivo pagato
	21%	9559,00	2007,39	
	ALIQUOTA	IMPONIBILE	IMPOSTA	Corrispettivo non pagato
Totale				Totale documento € 11.566,39

EDI 790 E 5340 C

SA0775578/11

1

DATA REG.
PROT. N.

ADOLFO ORSI

Allegato 7
RAFFAELE GAZZI

CLASSIC CAR AUCTION YEARBOOK

2009 | 2010



HS

HISTORICA SELECTA

11 YEARBOOK
 LOT AUCTION HOUSE
 122 Coy
 59 His and has been
 324 Bon F48
 332 Coy
 36 H&H
 320 Bon
 342 Bon
 306 Bon
 323 Bon F49
 164 as
 F50
 23 RM
 ar is
 F51
 05 RM
 F52
 65 Bon
 0 Bon Bonhams
 5 Bon
 7 Bon F53
 Goo
 2 Bon
 2 RM
 e. F54

YEAR	Model	(Bodybuilder)	CHASSIS NO.	STEERING	ESTIMATE	HAMMER PRICE			DATE	PLACE
						£	\$	€		
1954	Aston Martin DB2/4 spider	(Bertone)								
1958	DB MkIII coupé		AM30031462	LHD	140-180.000 EUR	163.257	264.928	188.106	07-11-2010	Paris
Green with red leather interior; built with the three Weber carburettor type DBB competition engine, the car was fully restored at unspecified date and two years hand drive.										
1957	DB MkIII coupé		AM30031414	RHD	50-70.000 GBP	52.650	82.529	62.143	06-12-2010	Weyl
Grey and black with grey leather interior; body repainted in 1992. Unused in the past years, it requires some restoration work.										
1958	DB MkIII coupé		AM30031386	LHD	200-250.000 USD		NS		20-01-2011	Phoe
Ivory with black leather interior; until 2009 in its first ownership, the car has covered 44,000 miles and is described as in very good original condition.										
1959	DB MkIII coupé		AM30031564	LHD	200-250.000 USD	110.405	176.000	130.170	22-01-2011	Scot
Red with original biscuit leather interior; body repainted in the late 1980s. In largely original condition, the car remained for 51 years with its first owner and h approximately 51,000 miles.										
1957	DB MkIII coupé		AM30031341	LHD	80-120.000 EUR	108.690	176.038	128.074	03-02-2011	Pari
Dark green with tawny leather interior; described as in good driving order.										
1958	DB MkIII coupé		AM30031696	RHD	90-120.000 EUR	92.924*	149.510*	109.684*	04-02-2011	Pari
Green with original red leather interior; restored between 1980 and 1994, the car was subsequently stored from 1996 to 2007. Described as in good driving ord 9.5.09).										
1958	DB MkIII coupé		AM30031502	RHD	80-120.000 EUR	80.934*	130.218*	95.531*	04-02-2011	Par
Green; raced in period, between 1999 and 2000 the car was fully prepared for use on track and fitted with a 270bhp engine. Offered with its original parts nece re-conversion to road use (see lot 326 Bonhams 22.5.10).										
1957	DB MkIII coupé		AM30031315	LHD	160-190.000 EUR		NS		05-02-2011	Par
Red; in very good overall condition. Engine rebuilt.										
1958	DB MkIII coupé		AM30031727	LHD	180-220.000 USD	134.127	214.500	155.748	11-03-2011	An
Blue with light grey leather interior; body repainted at date unspecified (see lot 244 RM 20.8.05).										
1959	DB MkIII coupé		AM30031497	LHD	135-185.000 USD	92.857	148.500	107.826	12-03-2011	An
Green with tan leather interior; since 1969 in the current ownership, the car has been restored over a number of years.										
1958	DB MkIII coupé		AM30031560	LHD	130-170.000 EUR	131.119	212.843	149.500	20-05-2011	M
Metallic grey with blue leather interior; partially restored, it's described as in very good overall condition (see lot 112 Sotheby's 9.9.97).										
1957	DB MkIII coupé		AM3003B1401	RHD	15-17.000 GBP	54.300	88.145	61.913	21-05-2011	Ne
Stored since 1971, it requires full restoration. First production MkIII with front disc brakes.										



F51: 1954 Aston Martin DB2/4 spider (Bertone)



F52: 1956 Aston Martin DB2/4 MkII notchback coupé



F53: 1955 Aston Martin DB2/4 MkII cabriolet (Tickford)

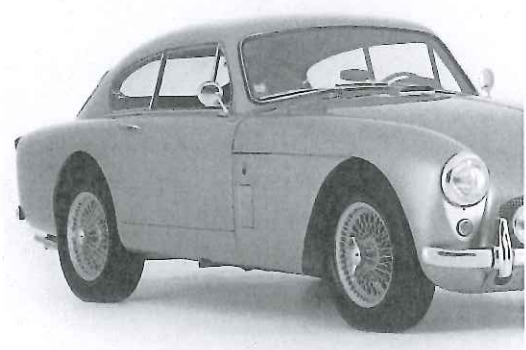

F54: 1957 Aston Martin DB MkIII coupé

YEAR	Model	(Bodybuilder)	CHASSIS NO.	STEERING	ESTIMATE	HAMMER PRICE			DATE	SALE PLACE
						£	\$	€		
1954	DB2/4 coupé		LML569	RHD	95-120.000 EUR		NS		14-08-2010	Nürburgring
<i>Red; in the early Eighties prepared for historic racing (see lot 32 Poulain 22.6.98).</i>										
1954	DB2/4 coupé		LML659	RHD	65-75.000 GBP	63.000	99.005	73.817	25-09-2010	Brooklands
<i>The car was bought new by English driver Noel Cunningham-Reid and raced at some events until 1955. The actual engine no. VB6E/50/1413 was fitted by factory in 1956 rebuilt in 1969. The car is unused from the early Seventies and requires restoration prior to use.</i>										
1955	DB2/4 coupé		LML785	LHD	200-240.000 EUR	282.541	454.594	333.500	05-02-2011	Paris
<i>Dark red with beige leather interior; between 2001 and 2008 fully restored to concours condition. First owner King Baudouin of Belgium.</i>										
1956	DB2/4 coupé		LML933	RHD	80-90.000 GBP		NA		08-03-2011	London
<i>Blue with blue leather interior; restored in the early 1990s. Engine overhauled in 2009.</i>										
1954	DB2/4 coupé		LML656	RHD	35-40.000 GBP	72.600	118.251	81.588	13-04-2011	Buxton
<i>Grey with dark red leather interior; stored since 1969, the car is described as complete with sound bodywork, old paintwork and free engine.</i>										
1955	DB2/4 coupé		LML888	RHD	90-130.000 GBP	73.000	118.501	83.235	21-05-2011	Newp.Pagnell
<i>British racing green with tan interior; restored over the years.</i>										
1955	DB2/4 coupé		LML1030	RHD	70-90.000 GBP	95.000	154.214	108.319	21-05-2011	Newp.Pagnell
<i>Grey with red interior; restored in 1989-90. 18,500 miles covered from new.</i>										
1955	DB2/4 cabriolet (Mulliners)		LML902	RHD	100-130.000 GBP		NS		21-05-2011	Newp.Pagnell
<i>Ivory with red leather interior; unrestored, it's described as in good original condition.</i>										
1955	DB2/4 cabriolet		LML1062	RHD	120-140.000 GBP	139.000	225.639	158.488	21-05-2011	Newp.Pagnell
<i>Green with beige leather interior; in the 1980s fully restored. At date unknown it was fitted with a 1953 Vantage engine.</i>										
1954	DB2/4 cabriolet (Bertone)		LML506	LHD	500-700.000 GBP	606.500	970.946	670.183	01-07-2011	Goodwood
<i>Blue with beige leather interior; sold new to the USA, in the mid-1980s the car was bought by Innes Ireland and imported into England. After some ownership changes, it subjected to a full restoration recently completed at a cost just under £ 200,000. Described as in concours condition, the car has covered 30 miles from the restoration.</i>										
1954	DB2/4 spider (Bertone)		LML507	RHD	700-900.000 EUR	589.378	956.726	672.000	21-05-2011	Villa d'Este
<i>One of three examples built on a Franco Scaglione design; sold new to the USA, the car was raced until the late Fifties. In the same ownership for 38 years from 1969, the car described as in original, unrestored condition (see lot 126 Gooding 16.8.09).</i>										
1956	DB2/4 MkII notchback coupé (Tickford)		AM3001241	RHD	95-110.000 GBP	103.600	163.926	118.757	27-10-2010	London
<i>Two tone blue with grey-blue leather interior; restored at unspecified date, it's described as in good overall condition. One of just 34 examples built.</i>										
1957	DB2/4 MkII coupé		AM3001202	RHD	50-70.000 GBP	52.650	82.529	62.143	06-12-2010	Weybridge
<i>Red with tan leather interior; restored in 1986, the car has not been used in the last years and requires recommissioning prior to use.</i>										
1956	DB2/4 MkII coupé (Tickford)		AM3001241	RHD	155-185.000 EUR		NS		20-05-2011	Monaco
<i>See lot 205 RM 27.10.10.</i>										
1957	DB2/4 MkII cabriolet (Tickford)		AM3001281	RHD	140-180.000 EUR		NS		11-09-2010	Reims
<i>Grey with blue leather interior; several restoration works carried out in 1987 and in the early 1990s. Some mechanicals works carried out in more recent years (see lot 171 12.5.01).</i>										
1956	DB2/4 MkII cabriolet (Tickford)		3001137	LHD	215-245.000 USD	141.553	218.750	171.916	12-09-2010	Westport
<i>White with dark red leather interior; restored in recent years (see lots 820 Bonhams 10.10.03, 191 RM 13.3.04, 268 Bonhams 7.6.09 and 28 Gooding 12.3.10).</i>										
1955	DB2/4 MkII cabriolet (Tickford)		AM3001104	RHD	180-200.000 GBP	227.000	368.489	258.825	21-05-2011	Newp.Pagnell
<i>Cream with blue leather interior; fully restored between 1996 and 2000 and recently recommissioned (see lots Bonhams 221 10.5.03, 335 17.5.08 and 215 18.9.09).</i>										
1958	DB MkIII coupé (Tickford)		AM30031376	LHD	150-200.000 USD	88.222	137.500	107.430	14-08-2010	Pebble Beach
<i>Gold with its original black leather interior; for 39 years with its previous owner, the car remained unused for many years and has been recently prepared for road use.</i>										
1958	DB MkIII coupé		AM30031532	RHD	90-110.000 GBP	98.300	153.613	117.616	17-09-2010	Goodwood
<i>Red with light grey leather interior; the body was repainted in the 1980s and requires some attention. The engine and gearbox have been rebuilt in 2003.</i>										
1957	DB MkIII coupé		AM30031310	LHD	115-145.000 GBP	207.200	327.853	237.513	27-10-2010	London
<i>Silver with red leather interior; fully restored in 2008. Ordered with optional front disc brakes, in 1958 the car was fitted with the present factory DBB competition-spec engi</i>										



F49: 1955 Aston Martin DB2/4 cabriolet



F50: 1954 Aston Martin DB2/4 cabriolet (Bertone)

ADOLFO ORSI RAFFAELE GAZZI

CLASSIC CAR AUCTION YEARBOOK 2010 2011

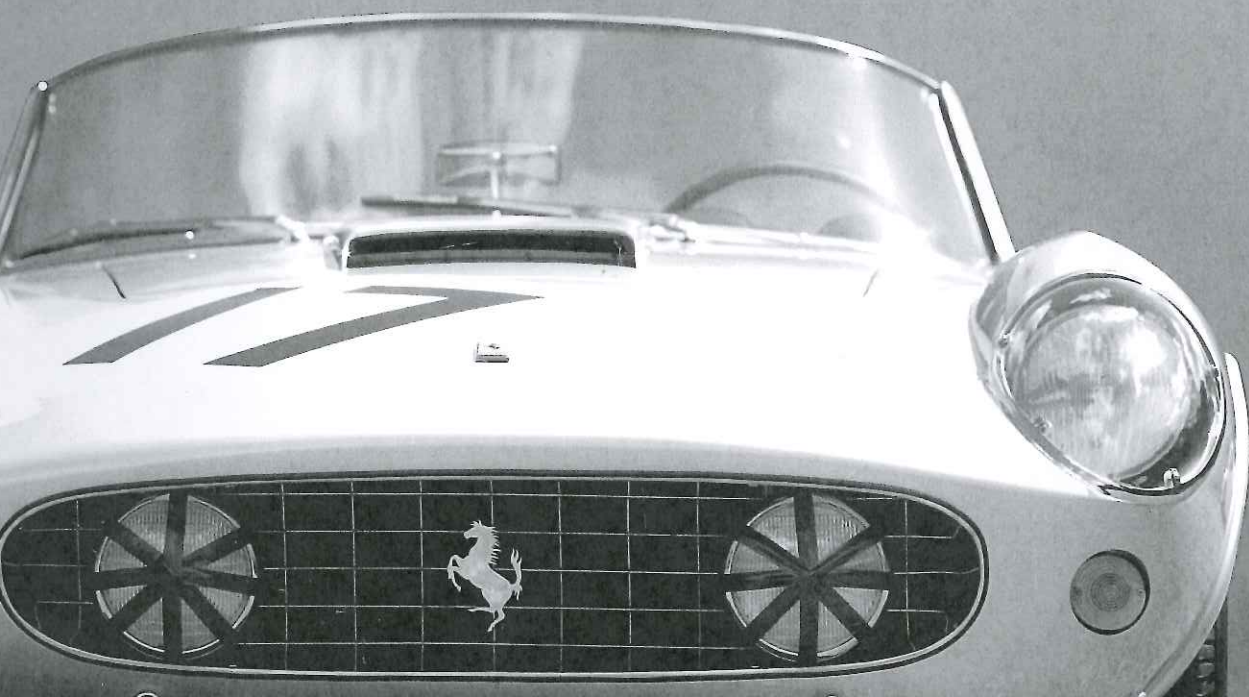

YEAR	Model	(Bodybuilder)	CHASSIS NO.	STEERING	ESTIMATE	HAMMER PRICE			SALE	
						£	\$	€	DATE	PLACE
1950	DB2 coupé		LML5012	RHD	190-240.000 GBP	199.500	286.442	229.226	22-05-2010	Newp. Pagnell
<i>Blue with beige leather interior; second production example built and sold new in the US, the car was fully restored in the Nineties. In the early 2000s it was fitted with the 3-liter engine (see lot 776 Bonhams 6.7.01).</i>										
1954	DB2/4 coupé		LML737	RHD	65-85.000 GBP	89.400	131.051	107.262	02-06-2010	Brooklands
<i>Black with magnolia leather interior; taken off the road in 1973, in 2007 the car was acquired by the present owner and mechanically restored. The paintwork and interior original, engine has been rebuilt, clutch replaced and gearbox overhauled.</i>										
1953	DB2/4 cabriolet (Bertone)		LML504	LHD	Refer Dpt.	994.455	1.650.000	1.155.000	15-08-2009	Pebble Beach
<i>Red with red leather interior; at unspecified date fully restored to concours condition. One of just two examples built by Carrozzeria Bertone on a Giovanni Michelotti design. From the Michael Schudroff collection (see lot 2267 RM 21.4.07).</i>										
1954	DB2/4 cabriolet (Mulliners)		LML839	RHD	70-90.000 GBP	150.000	215.370	172.350	22-05-2010	Newp. Pagnell
<i>Burgundy with black leather interior; the car was raced in the 1962 and 1963 Targa Florio and in 1970 was acquired by the current owner who had it fully restored in 1976 as in very good mechanical order; the paintwork requires some attention.</i>										
1955	DB2/4 cabriolet		LML913	RHD	110-130.000 GBP	162.037	237.530	194.412	02-06-2010	Brooklands
<i>Red with light grey leather interior; since 1983 in the same ownership. Engine rebuilt between 1996 and 1998, interior replaced in 1997.</i>										
1954	DB2/4 spider (Bertone)		LML507	LHD	Refer Dpt.	629.822	1.045.000	731.500	16-08-2009	Pebble Beach 1
<i>Red with red interior; described as in largely original condition except for the paintwork, the car has covered just 14,500 miles. One of three spiders ordered by Wacky Arno built by Bertone on a Franco Scaglione design. The car was raced in USA until the late Fifties. From the Michael Schudroff collection.</i>										
1955	DB3S		DB3S104	RHD	1.750-2.250.000 USD	1.189.386	1.980.000	1.385.208	15-08-2009	Monterey 5t
<i>"Customer" car; it was sold to the Australian Kangaroo Stable team which raced it at some European events before to resale the car to the American driver Rod Carveth. Raced in USA till the late Fifties, the car was first restored in the Seventies. Back to England, it received another restoration between 1989 and 1992 and was again finished with the A Martin racing color of green metallic.</i>										
1957	DB2/4 MkII coupé		AM3001234	RHD	38-45.000 GBP	49.900	81.487	55.424	18-09-2009	Goodwood 23
<i>Green with black leather interior; since 1973 in the same family ownership, the car was restored in 2005.</i>										
1956	DB2/4 MkII coupé		AM3001206	LHD	175-225.000 USD	105.710	170.500	120.629	23-01-2010	Scottsdale 11
<i>Two tone grey with red leather interior; restored in 1996.</i>										
1955	DB2/4 MkII cabriolet (Tickford)		AM3001104	RHD	110-130.000 GBP	181.900	297.043	202.036	18-09-2009	Goodwood 21
<i>Cream with blue leather interior; fully restored to concours condition between 1996 and 2000 (see lot 335 Bonhams 17.5.08).</i>										
1956	DB2/4 MkII cabriolet		AM3001137	LHD	225-275.000 USD		NS		12-03-2010	Amelia Island 28
<i>White with dark red leather interior; restored in the early 2000s (see lots 820 Bonhams 10.10.03, 191 RM 13.3.04 and 268 Bonhams 7.6.09).</i>										
1959	DB MkIII coupé		AM30031806	RHD	200-250.000 USD		NS		15-08-2009	Pebble Beach 72
<i>Red with tan leather interior; restoration completed in 2008. 180bhp DBD engine.</i>										
1958	DB MkIII coupé		AM30031725	LHD	175-225.000 USD	170.115*	275.000*	195.525*	21-01-2010	Phoenix 120
<i>Blue with black leather interior; in the Nineties fully restored to concours condition. Since 1959 in the same ownership.</i>										
1957	DB MkIII coupé		AM30031342	LHD	120-150.000 EUR	105.813	170.680	120.750	23-01-2010	Paris 266
<i>Dark green with red leather interior; engine and gearbox overhauled in 1993, body repainted in 2000, front disc brakes fitted in recent years (see lot 115 Christie's 8.7.06).</i>										
1958	DB MkIII coupé		AM30031615	RHD	120-150.000 EUR	116.605	178.398	133.983	30-04-2010	Monaco 225
<i>Metallic blue with grey interior; restored in 2009.</i>										
1957	DB MkIII coupé		AM3003A1309	LHD	90-120.000 EUR	116.968	178.954	134.400	01-05-2010	Monaco 296
<i>Blue with silver roof and cream leather interior; restored in recent years.</i>										
1958	DB MkIII coupé		AM30031502	RHD	70-90.000 GBP	73.000	104.813	83.877	22-05-2010	Newp. Pagnell 326
<i>Green; restored in the late 1980s and used in historic racing from 1993 to 2005. In 2001 fitted with a 270bhp engine. Offered with also all the original parts necessary for the re-conversion to a road car.</i>										
1958	DB MkIII coupé		AM30031533	RHD	85-100.000 GBP	93.500	135.958	113.210	09-06-2010	Buxton 39
<i>Dark green with red leather interior; body and interior restored in the early 1980s. Mechanicals overhauled in recent years (see lots 452 Brooks 23.6.95 and 12 Coys 30.4.96).</i>										
1958	DB MkIII cabriolet		AM30031402	LHD	300-400.000 USD	204.138*	330.000*	234.630*	21-01-2010	Phoenix 119
<i>Blue with grey leather interior; between 2000 and 2001 fully restored to concours condition.</i>										
1963	DB4 Vantage GT coupé (Touring/Tickford)		DB41144R	RHD	500-600.000 USD		NS		14-08-2009	Carmel 240
<i>Dark green; one of six DB4 Series 5 examples built with the GT Twin-Plug engine. Restored in the Eighties; the original GT block was replaced with a larger 4.0-liter block and the chassis was fitted with a DB5 five-speed transmission and rear-end.</i>										
1960	DB4 coupé (Touring/Tickford)		DB4358L	LHD	275-325.000 USD	139.224*	231.000*	161.700*	16-08-2009	Pebble Beach 140
<i>Red with black leather interior; engine rebuilt in 1995, paintwork and interior replaced in 2006. From the Michael Schudroff collection.</i>										
1961	DB4 coupé (Touring/Tickford)		DB4673R	RHD	80-110.000 GBP		NS		03-10-2009	Ascot 221
<i>Red with black leather interior; described as in good overall condition (see lots Coys 320 20.10.07 and 330 3.3.08).</i>										
1961	DB4 coupé (Touring/Tickford)		DB4682R	RHD	100-140.000 GBP	110.000	179.564	121.451	28-10-2009	London 220
<i>British racing green; the car has had a long race career from 1961 to 1996 when it was fully overhauled and the engine was rebuilt. During its race life the car took 42 podium finishes and 9 victories.</i>										
1959	DB4 coupé (Touring/Tickford)		DB4203R	RHD	100-115.000 GBP		NS		01-12-2009	London 425
<i>Red with black leather interior; restored at unspecified date (see lots Bonhams 161 12.5.01 and 123 4.6.05, and Coys 126 30.11.06).</i>										



ASTON MARTIN

Technical Data Sheet

17th January 2011

Aston Martin DB2/4 Mk I

Vehicle Identification Number	: LML/906
Engine Number	: VB6J/413
Year of Manufacture	: 1955
Body Style	: 2dr coupe
Length	: 4305 mm
Wheel Base	: 2515 mm
Width	: 1651 mm
Height	: 1359 mm
Kerb Weight	: 1257 kg
Powered Axle	: Rear
Wheel Size	: 6.0 J x 16
Transmission	: Manual, 4 speed
Engine Capacity	: 2580 cm ³
Number of Cylinders and configuration	: 6, upright inline
Working principle	: Positive Ignition, Four Stroke,
Fuel Delivery	: 2 x SU Carburettors
Maximum Power	: 126.7 PS
Maximum Torque	: 195 Nm @ 2400rpm
Maximum Vehicle Speed	: 179 km/h

Manufactured by Aston Martin Lagonda Limited, Feltham, England.

For and on behalf of
Aston Martin Lagonda Limited

S. Wiles

Stephen Wiles
Legislation & Certification Manager



MARCA OPERATIVA E DATA: **13 MAR 227903** TARIFFA: **09.03.11** OPERAZIONE A SEGUITO DI: **23** CLASSE VEIC.: **1** TARGA: **ZB 145AC**

TIMBRO O CODICE IMPRESA DI CONSULENZA
SOLCI SRL
Cod. 1002

Dipartimento dei Trasporti Terrestri, all'Ufficio Provinciale di **MANTOVA**
Il sottoscritto, consapevole delle sanzioni penali previste dall'art. 26 della legge 4 gennaio 1968, n. 15, per le ipotesi di falsità in atti e dichiarazioni mendaci, dichiara, ai sensi dell'art. 2 della medesima legge n. 15/1968, così come Integrato dall'art. 1 del D.P.R. 20 ottobre 1998, n. 403, di essere:

1) _____
e chiede: **143**

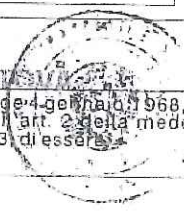

DATI ANAGRAFICI DEL PROPRIETARIO DEL VEICOLO

COGNOME O DENOMINAZIONE / SOC. ENTITA': **STEFANO RICCI**
 NOME / OPPURE SEGUE DENOMINAZIONE: _____
 DATA DI NASCITA: _____ STATO EST. NASC.: _____ PROV.: _____ COMUNE DI NASCITA: _____ CODICE REGIONE: **SP**
 RESIDENTE NEL COMUNE DI: **FIRENZE**
 NUMERO, VIA: **26 DEI NICCOLI** PROV. DI RESID.: _____ N. ALTRI PROP.: _____ CAUSALE AGGIORNAMENTO: _____

DATI DEL VEICOLO

FABBRICA E TIPO: **ASTON MARTIN DB24 MK1** USO (SE FT. SPECIFICARE): **P T**
 CLASSIFICAZIONE: **AUTOVETTURA** N. OMOLOGAZIONE: **4172590340/14** CAT./MA: _____ COD. USO: **40**
 N. DI TELAI: **LML/906** ANNO I. I. M.: **1956** CODICE VEICOLO: _____
 TARGA PRECEDENTE: _____ TIPO COD. CODICE FISCALE O PARTITA IVA: **V 01874990184**

CODICE: **AD** POT. FISC.: _____ SIDI FISC.: **20** COD. CARRICAZ.: _____ POSTI ANT.: _____ POSTI TOTALI: _____ LUNGHEZZA (mm): **14.305** LARGHEZZA (mm): **1.651** SQUALZO POSTI: _____ N. PIAENTE: _____
 PARA (kg): _____ MASSA COMPL. (kg): _____ RAP. AL PONTE: _____ MASSA RM. (kg): _____ AVANZ. RALLA (mm): _____ N. ASSI: _____ INTERASSE (mm): _____
 INTERASSE (mm): **1.257** INTERASSE (mm): _____ INTERASSE (mm): _____ CAPACITA' POTENZA (kg): _____ MASSA POT. COMPL. (kg): _____ MARCA OPERATIVA: **0071589006** REVISIONE (DATA): **06/05/12**
 FABBRICA E TIPO - INTEGRATIVO DENOMINAZIONE DI O.M.: _____ VEL. MAX EFF.: _____
 CLOR: _____ MARCA O.M. DELLA PREC. VISITA E PROVA DATA: _____ RAP. POT./TARGA: _____
 REG. GANCIO DI TRAINO ALIMENTAZIONE
 RIP. ALIMENTAZIONE BENZINA/GPL

TRASPORTO COSE - NOLEGGI E SERVIZI PUBBLICI - LICENZA NOLEGGIO MACCHINE AGRICOLE

ESLENTE - N. AUTORIZZ. O N. LICENZA: _____ DATA DI LASCIO: _____ ATTIVITA' TRASPORTO COSE O AUTORIZZ. CONCEDENTE IL TITOLO: _____

MACCHINE AGRICOLE E OPERATRICI

DENOMINAZIONE AZIENDA: _____ TITOLO AZIENDA: _____
 SEGUE DENOMINAZIONE AZIENDA: _____
 COMUNE SEDE DELL'AZIENDA: _____ PROV. O RES.: _____
 NUMERO, VIA: _____
 DICHIARAZIONE DI TITOLARIETA' **11**
 NUMERO: _____ DATA: _____

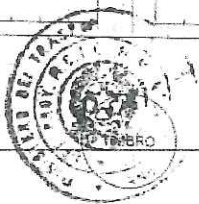

VISTA LA DOCUMENTAZIONE PRESCRITTA, SI AUTORIZZA LA CIRCOLAZIONE DEL VEICOLO SOPRA DESCRITTO MUNITO DELLA TARGA SUINDICATA.

VALIDITA' **60** GIORNI DALLA DATA DI EMISSIONE

DATA **11 APR. 2012**

COPIA DICHIARANTE

- CARTA PROVVISORIA DI CIRCOLAZIONE
- ESTRATTO DELLA CARTA DI CIRCOLAZIONE
- FOGLIO DI VIA
- AGGIORNAMENTO VARIAZIONE PROPRIETA' O RESIDENZA
- AGGIORNAMENTO PER INSTALLAZIONE GANCIO DI TRAINO E/O IMPIANTO A GAS

Assistente **De Concillis Dr. Giorgio**
 IL DIRETTORE

MARCA OPERATIVA E DATA: **13MM 227903** TARIFA: **09.03.1** OPERAZIONE A SEGUITO DI: **1** CLASSE VEIC.: **A** TARGA: **ZB 145AC**

TIMBRO O CODICE IMPRESA DI CONSULENZA
SOLCI SRL
Cod. 1002

Dipartimento dei Trasporti Terrestri, all'Ufficio Provinciale di **MANTOVA**
Il sottoscritto, consapevole delle sanzioni penali previste dall'art. 26 della legge 4 gennaio 1968, n. 15, per le ipotesi di falsità in atti e dichiarazioni mendaci, dichiara, ai sensi dell'art. 2 della medesima legge n. 15/1968, così come Integrato dall'art. 1 del D.P.R. 20 ottobre 1998, n. 403, di essere:

1) _____
e chiede: **1**

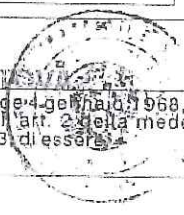

DATI ANAGRAFICI DEL PROPRIETARIO DEL VEICOLO

COGNOME O DENOMINAZIONE / SOC. ENTITA': **STEFANO RICCI**
NOME / COGNOME (SEGUE DENOMINAZIONE): _____
DATA DI NASCITA: _____ STATO EST. NASC.: _____ PROV.: _____ COMUNE DI NASCITA: _____ CODICE REGIONE: **SP**
RESIDENTE NEL COMUNE DI: **FIRENZE**
NUMERO VIA: **26 DEI NICCOLI** PROV. DI RES. U: _____ ALTRA PROP. U: _____ CAUSALE AGGIORNAM. U: _____

DATI DEL VEICOLO

FABBRICA E TIPO: **ASTON MARTIN DB24 MK1** USO (SE FT. SPECIFICARE): **P** SE 17- SPECIFICARE: **T**
CLASSIFICAZIONE: **AUTOVEETTURA** N. OMOLOGAZIONE: **4172959340MM/4** CAT/MA: _____ COD. USO: **40**
N. DI TELAI: **LML/906** ANNO 1° IMM.: **1955** CODICE VEICOLO: _____
TARGA PRECEDENTE: _____ TIPO COD. CODICE FISCALE O PARTITA IVA: **V. 01674990184**

CODICE: **AD** POT. FISC.: _____ EIB. FISC.: **20** COD. CARRICAZ.: _____ POSTI ANT.: _____ POSTI TOTALI: _____ LUNGHEZZA (mm): **4.305** LARGHEZZA (mm): **1.651** SQUALZI POSTI: _____ N. FREMTE: _____
TARA (kg): _____ MASSA COMPL. (kg): _____ PAPP. AL PONTE: _____ MASSA RM. (kg): _____ AVANZ. RALLA (mm): _____ N. ASSI: _____ INTERASSE (mm): _____
INTERASSE (mm): **1.257** INTERASSE (mm): _____ INTERASSE (mm): _____ CAPACITA' PORTATA (kg): _____ MASSA POT. COMPL. (kg): _____ MARCA OPERATIVA: **00171589208** REVISIONE (DATA): **06/05/12**
AMERICA E TIPO - INTEGRATIVO DENOMINAZIONE DI O.M.: _____ VLL MAX EFF: _____
CLOD - MARCA O.M. DELLA PREC. VISITA E PROVA DATA: _____ RAP. POT./TARA: _____
REG. GANCIO DI TRAINO ALIMENTAZIONE
RIP. ALIMENTAZIONE BENZINA/METANO

TRASPORTO COSE - NOLEGGI E SERVIZI PUBBLICI - LICENZA NOLEGGIO MACCHINE AGRICOLE

ESLENTE - N. AUTORIZZ. O N. LICENZA: _____ DATA FILASCIO: _____ ATTIVITA' TRASPORTO COSE O AUTORIZZ. CONCEDENTE IL TITOLO: _____

MACCHINE AGRICOLE E OPERATRICI

DENOMINAZIONE AZIENDA: _____ TIPO AZIENDA: _____
SEGUE DENOMINAZIONE AZIENDA: _____
COMUNE SEDE DELL'AZIENDA: _____ PROV. DI RES.: _____
NUMERO VIA: _____ DICHIARAZIONE DI TITOLARIETA' N. NUMERO: _____ DATA: _____

VISTA LA DOCUMENTAZIONE PRESCRITTA, SI AUTORIZZA LA CIRCOLAZIONE DEL VEICOLO SOPRA DESCRITTO MUNITO DELLA TARGA SUINDICATA.

VALIDITA' **60** GIORNI DALLA DATA DI EMISSIONE

DATA: **11 APR. 2012**

COPIA DICHIARANTE

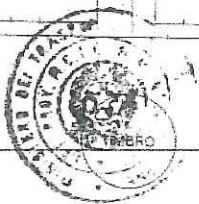

- CARTA PROVVISORIA DI CIRCOLAZIONE
- ESTRATTO DELLA CARTA DI CIRCOLAZIONE
- FOGLIO DI VIA
- AGGIORNAMENTO VARIAZIONE PROPRIETA' O RESIDENZA
- AGGIORNAMENTO PER INSTA. AZIONE GANCIO DI TRAINO E/O IMPIANTO A GAS

Assistente **De Concillis** **De Giorgi**
p. IL DIRETTORE

EMILIANAUTO BOLOGNA s.r.l.
Via De' Carracci n. 8/6
40131 BOLOGNA
C.F.eP.IVA 02595751203

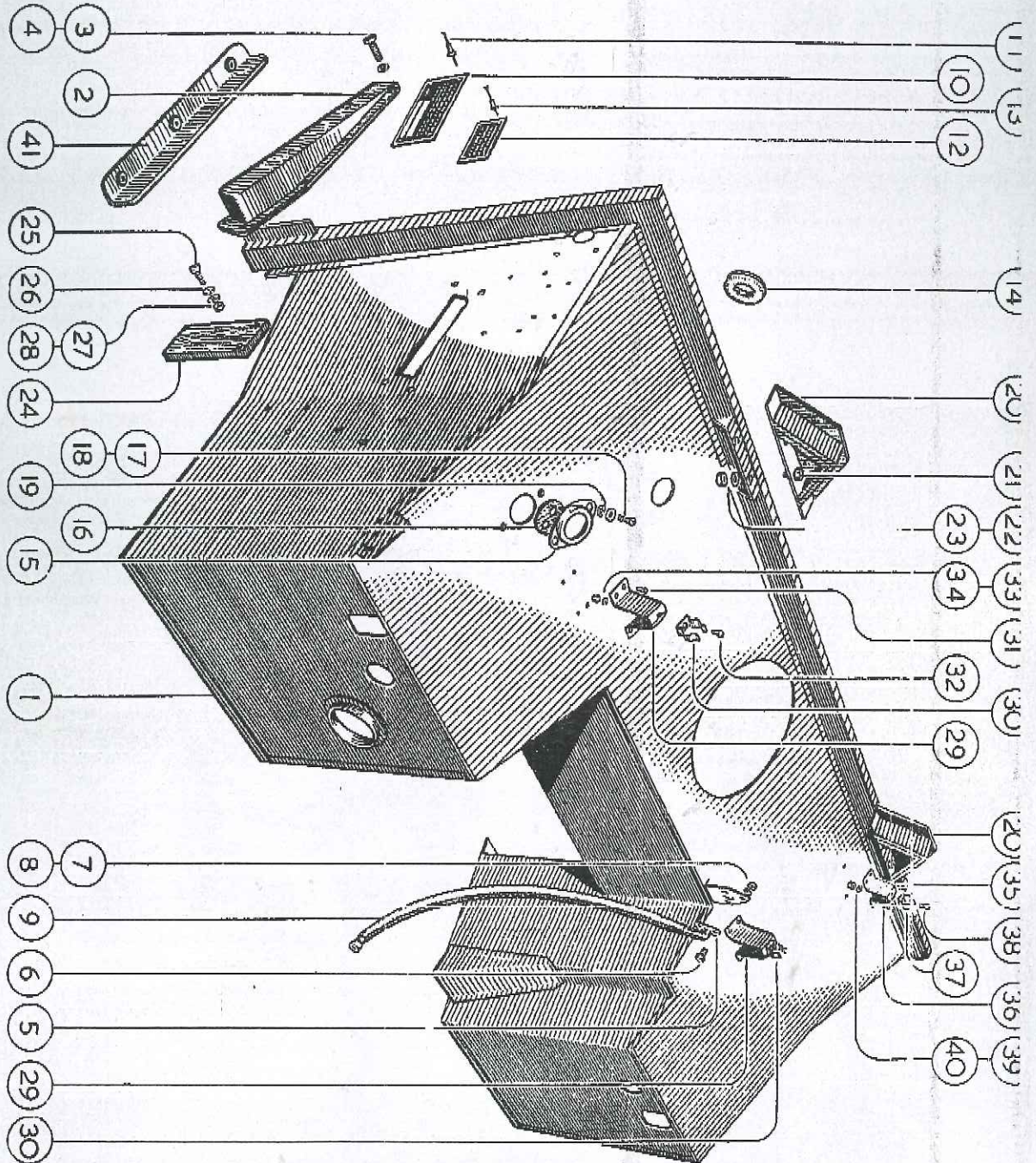

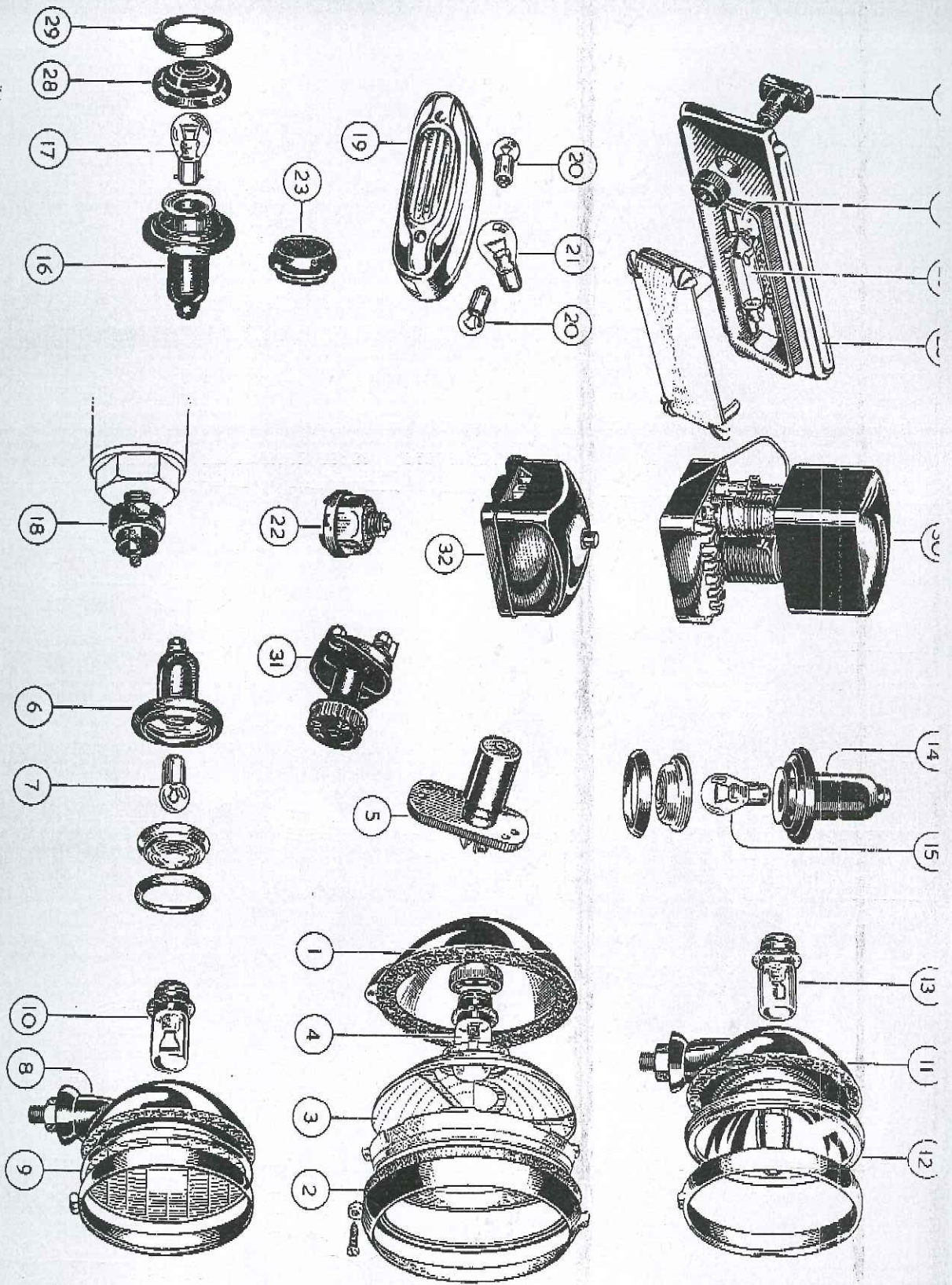

EMILIANAUTO BOLOGNA s.r.l.
 Via De' Carracci n. 8/6
 40131 BOLOGNA
 C.F. e P. IVA 02595751203

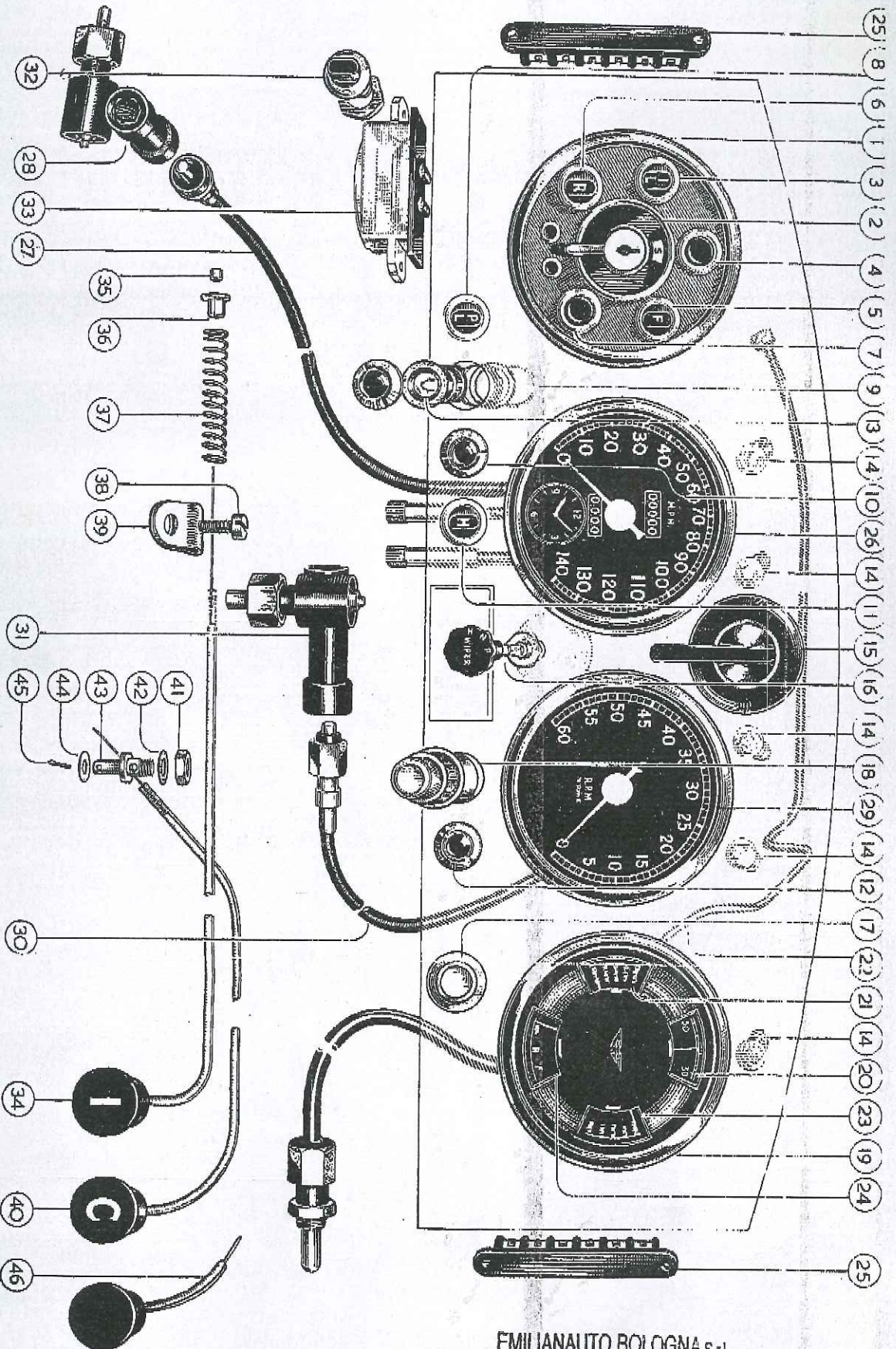

EMILIANAUTO BOLOGNA s.r.l.
 Via De' Carracci n. 8/6
 40131 BOLOGNA
 C.F.e.P. IVA 02595751203

EMILIAUTO BOLOGNA s.r.l.
Via De' Carracci n. 8/8
40131 BOLOGNA
C. F. e P. IVA 02595751203

